

THE MIXING PEOPLE

WALTER EQUIPMENT

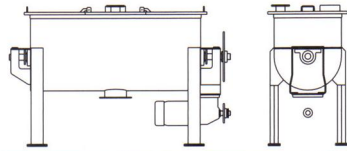

## RIBBON BLENDER

R-SERIES RIBBON BLENDER USES COUNTER FLOW FLIGHTS MOUNTED ON A LARGE DIAMETER SHAFT ENSURING GENTLE, POSITIVE HIGH SPEED MIXING IN A RIGID INTEGRAL ALL WELDED UNIT

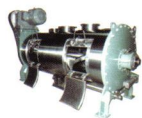

WE OFFER A COMPLETE LINE OF COMPONENTS FOR MIXING SYSTEMS WHICH INCLUDES: RIBBON BLENDERS, MEAT MIXERS, PLOUGH MIXERS, SIFTERS AND SCREW CONVEYORS. DETAILED BULLETINS ON THESE AND OTHER COMPONENTS ARE AVAILABLE UPON REQUEST OR VISIT [WWW.WALTEREQUIPMENT.COM](http://WWW.WALTEREQUIPMENT.COM)

# RIBBON BLENDER

## FEATURES

- HEAVY GAUGE, ALL STAINLESS STEEL SHELL WITH WELDED END PLATES – SANITARY DESIGN
- HELICAL GEAR MOTOR AND CHAIN DRIVE MAKES MOST EFFICIENT USE OF INPUT HORSEPOWER WITH COMPLETELY ENCLOSED STAINLESS STEEL CHAIN GUARD
- AIR PURGE SEALS ARE STANDARD
- FULL HEAVY GAUGE COVER
- HINGED SECTIONAL DOORS
- STANDARD 304/316 STAINLESS STEEL 2-B FINISH
- ALL MACHINES SUPPLIED C/W COVERS, MOTORS, DRIVES & GUARDS INSTALLED - NO EXTRAS TO BUY
- ALL WELDS ARE PERFORMED BY TUNGSTEN INERT GAS METHOD, GROUND SMOOTH AND GLASS BLASTED FOR UNIFORM FINISH

## OPTIONS

- DISCHARGE BUTTERFLY VALVE
- DISCHARGE SLIDEGATE VALVE
- PACKING GLAND SEALS AVAILABLE
- POLISHED FINISH AVAILABLE
- 3600 RPM CHOPPER
- DIRECT DRIVE HELICAL GEARMOTOR
- POLISHED FINISHED AVAILABLE

## INTERNAL

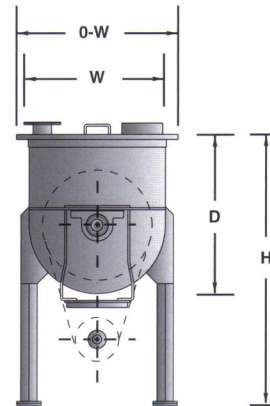
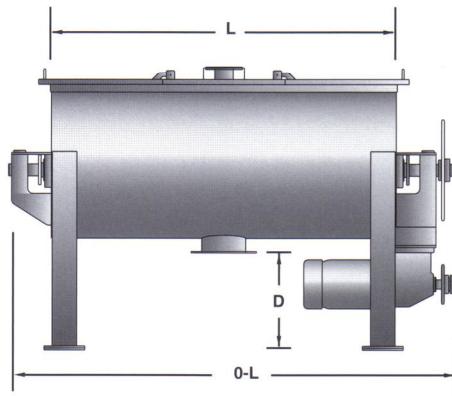
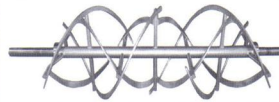

| MODEL NO. | FT <sup>3</sup> | M <sup>3</sup> | HP  | RPM | W    | L   | D    | O-L | O-L | CL | HT  |
|-----------|-----------------|----------------|-----|-----|------|-----|------|-----|-----|----|-----|
| R-6       | 0.17            | 0.085          | 2   | 55  | 17.5 | 44  | 20.5 | 65  | 22  | 30 | 55  |
| R-15      | 15              | 0.42           | 5   | 48  | 24   | 60  | 28   | 84  | 30  | 42 | 74  |
| R-23      | 23              | 0.65           | 7.5 | 45  | 27   | 68  | 31.5 | 92  | 33  | 42 | 78  |
| R-30      | 30              | 0.85           | 10  | 42  | 30   | 72  | 35   | 94  | 36  | 42 | 82  |
| R-45      | 45              | 1.27           | 15  | 40  | 33   | 84  | 38.5 | 108 | 40  | 42 | 85  |
| R-60      | 60              | 1.7            | 20  | 35  | 36.5 | 92  | 42.5 | 116 | 44  | 42 | 90  |
| R-75      | 75              | 2.12           | 25  | 32  | 40   | 94  | 47   | 120 | 47  | 42 | 94  |
| R-90      | 90              | 2.55           | 30  | 30  | 42   | 104 | 49   | 130 | 49  | 42 | 96  |
| R-120     | 120             | 3.4            | 40  | 27  | 48   | 120 | 56   | 145 | 56  | 42 | 102 |

ALL DIMENSIONS SUBJECT TO CHANGE WITHOUT NOTICE